

2- APPLICATIONS :

Pour chaque exercice, **tracer** la vue coupée manquante. **Utiliser** le plan de coupe indiqué. **Exercices 1-2-3-4: Faire** une coupe simple (classique).

EX1-

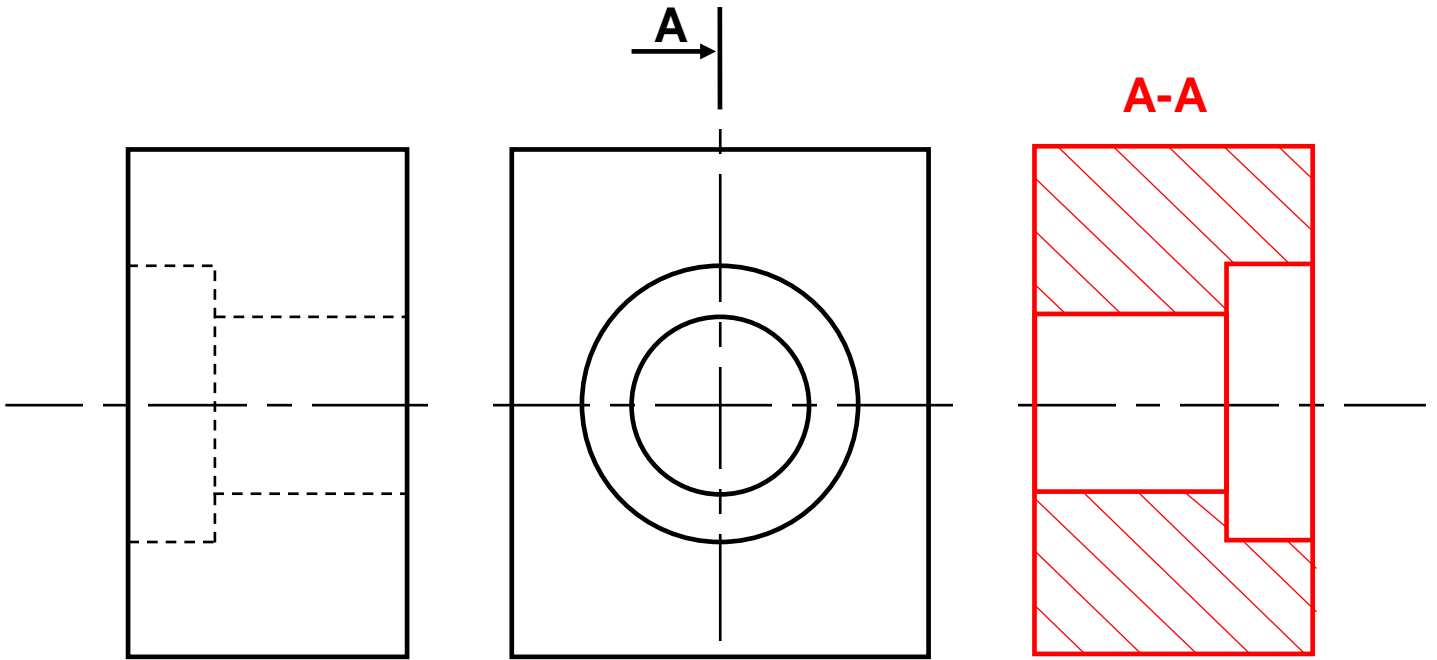

EX2

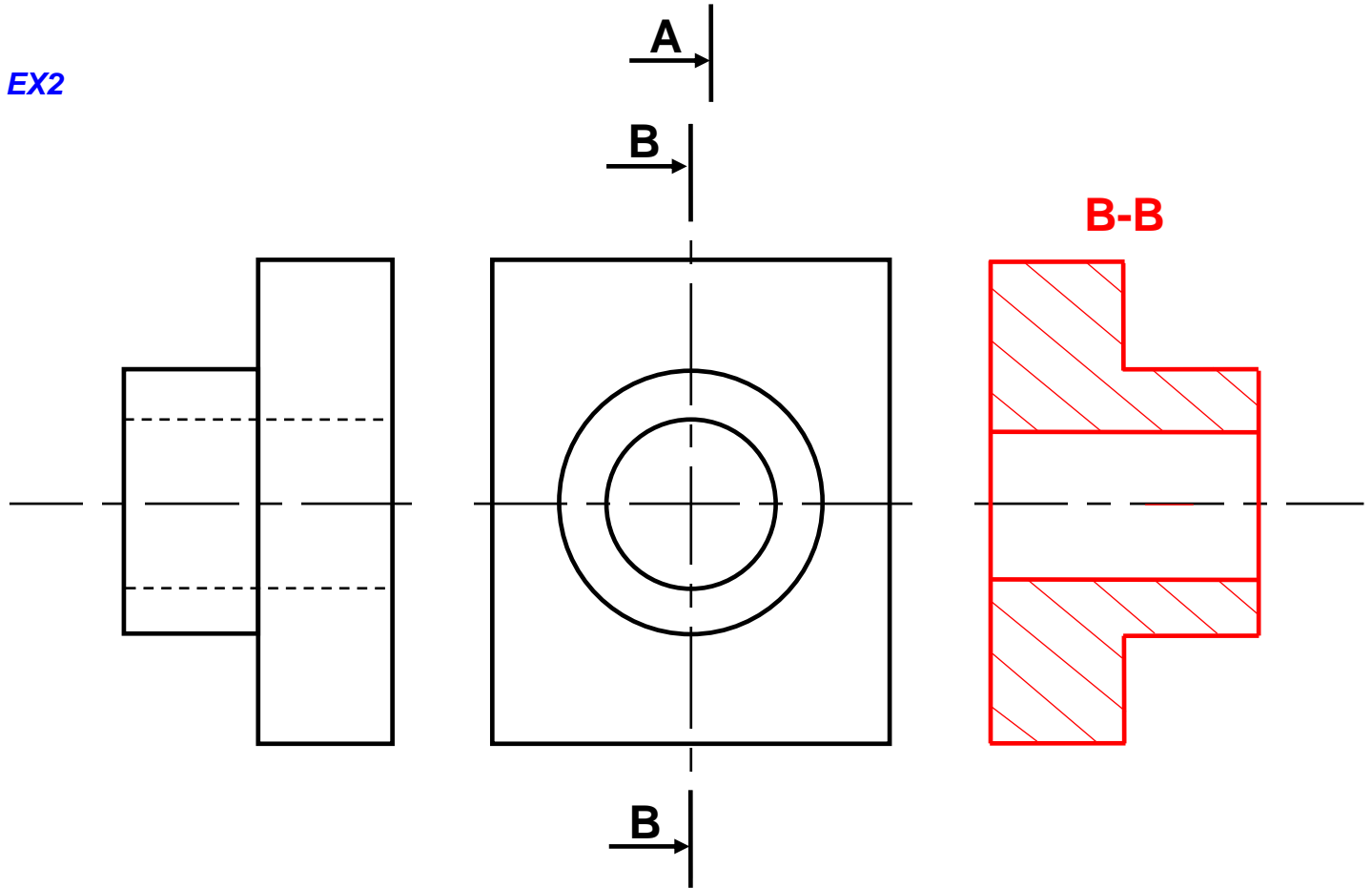

EX3-

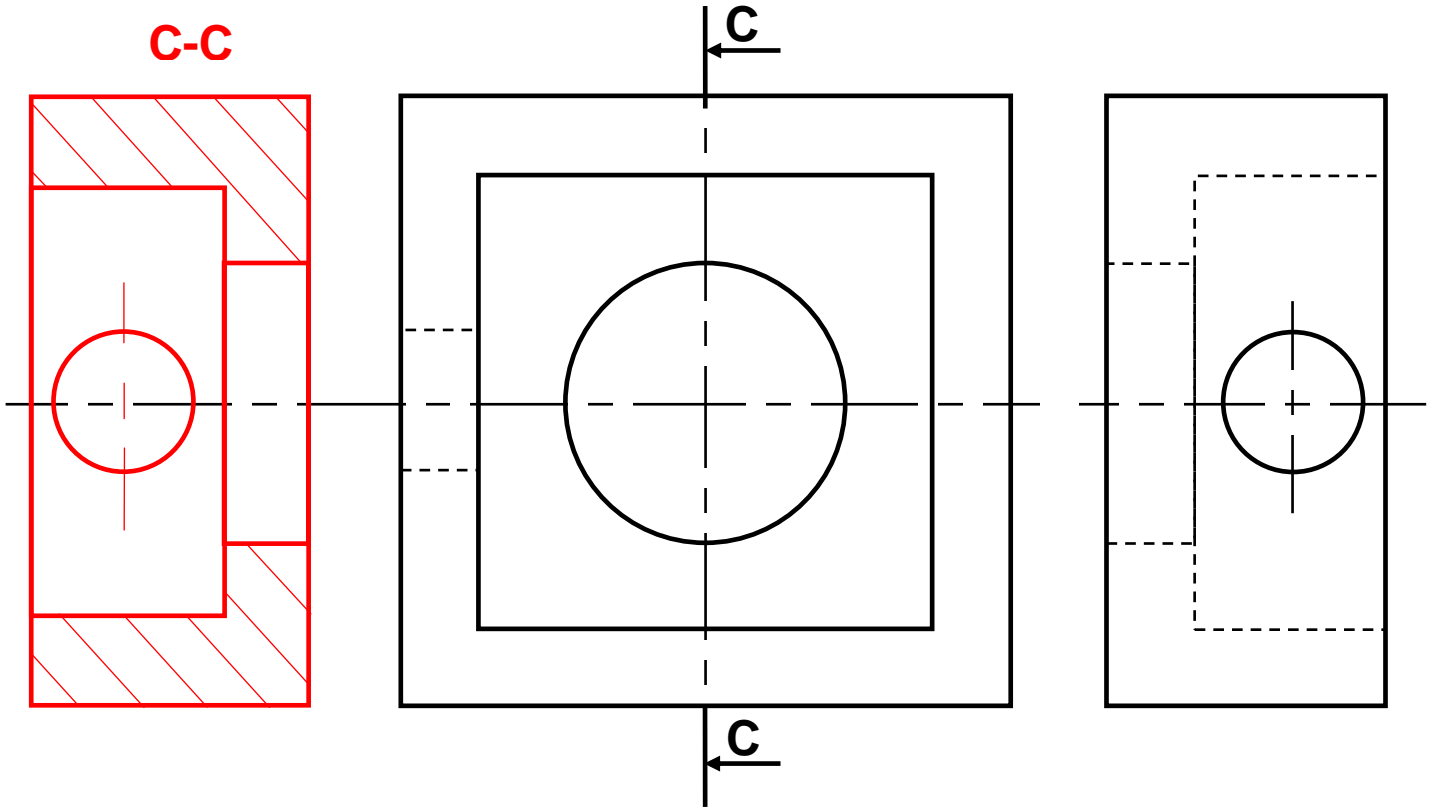

EX4-

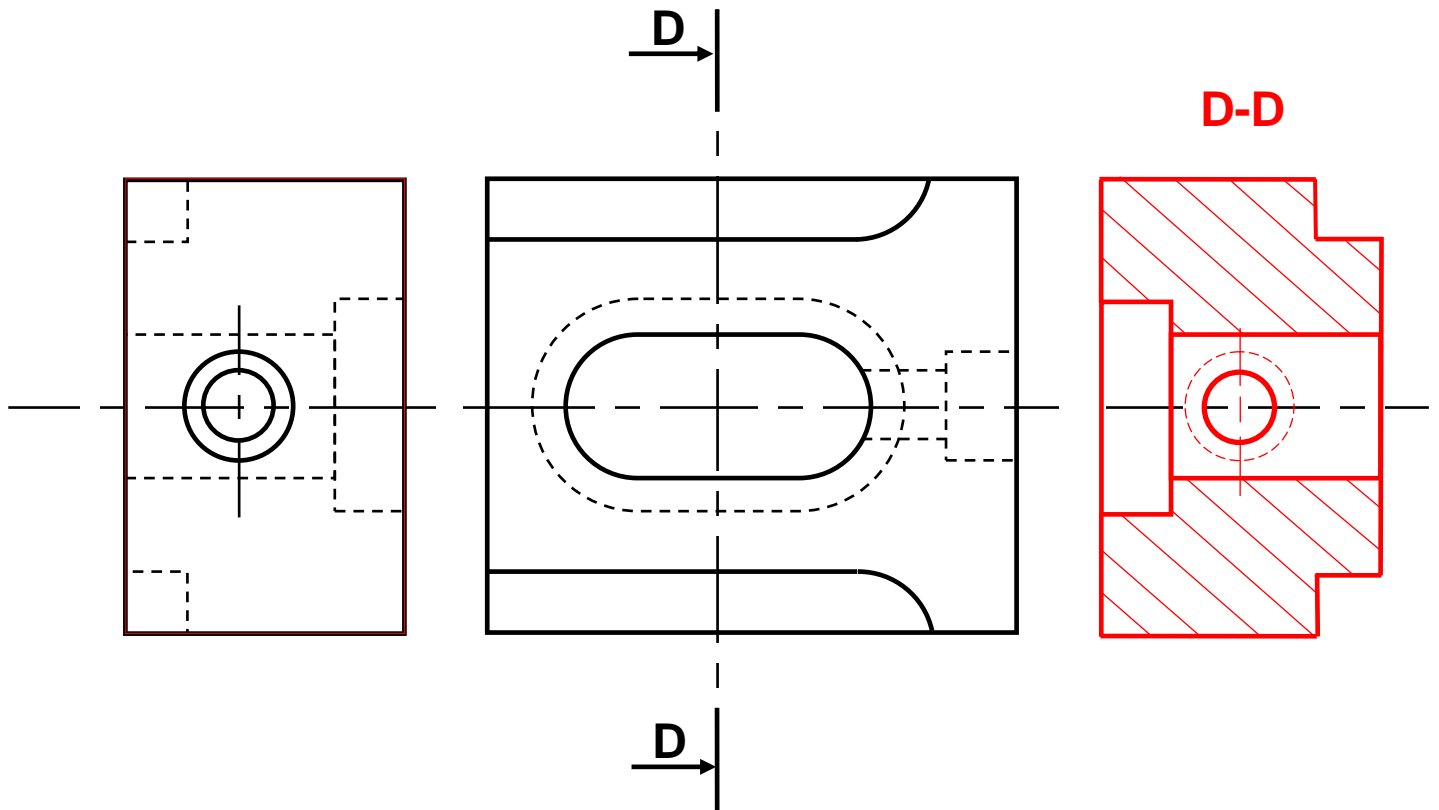

Pour chaque exercice, **tracer** la vue coupée manquante. **Utiliser** le plan de coupe indiqué. **Exercices 5-6-7** : **Faire** une demi-coupe.

EX5-

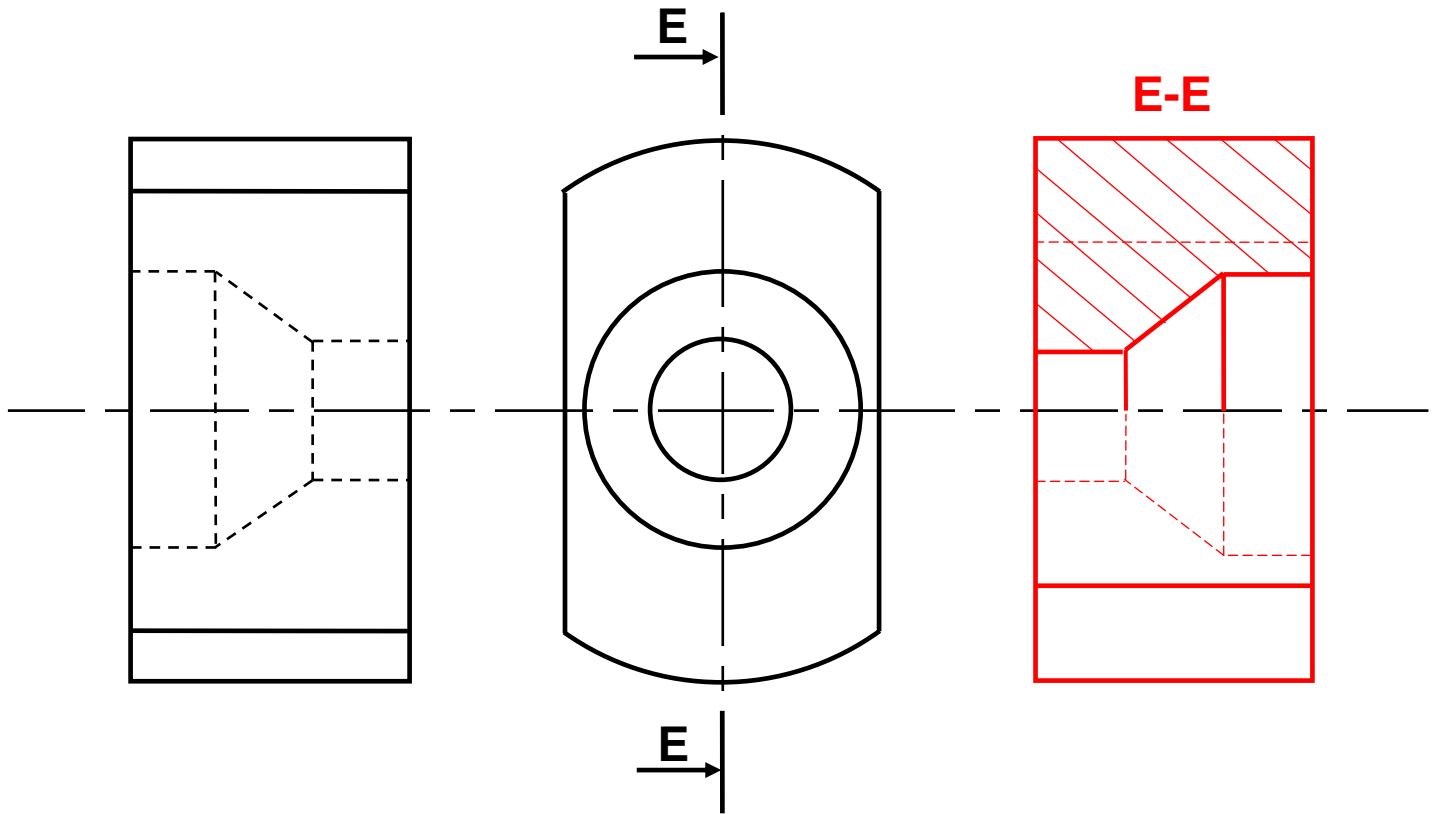

EX6-

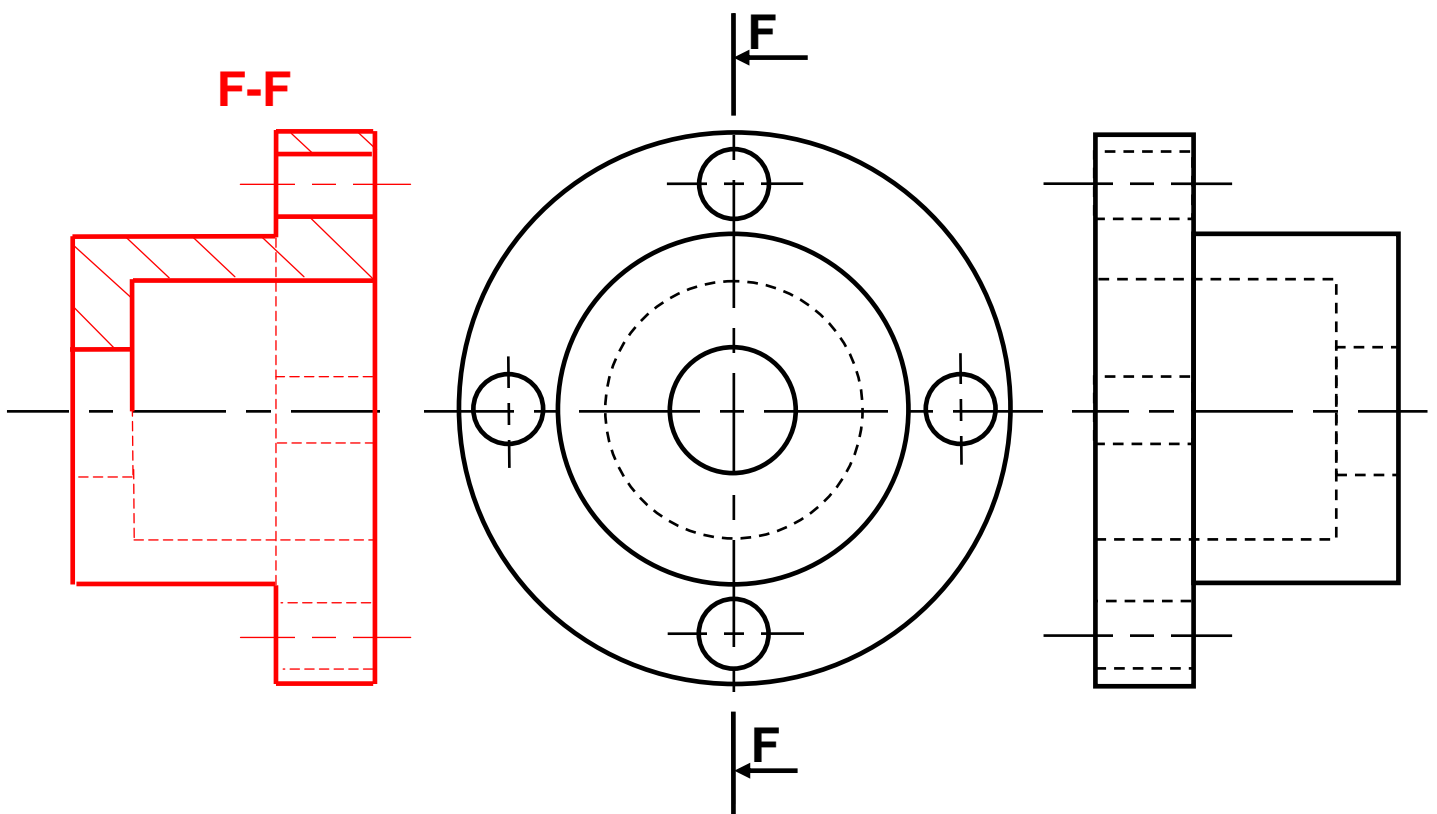

EX7-

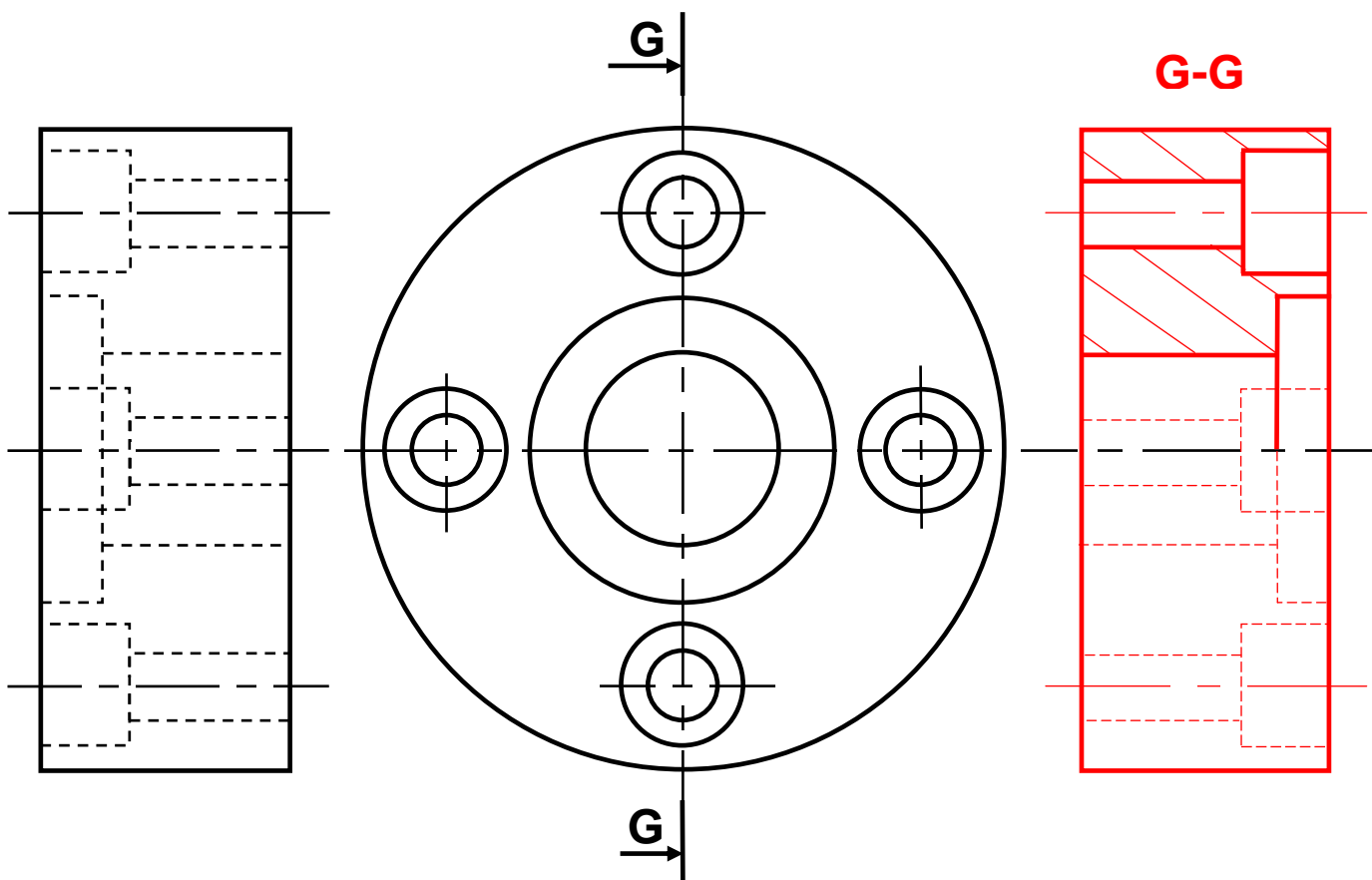

Pour cet exercice, **tracer** la vue coupée manquante. **Utiliser** le plan de coupe indiqué. **Exercice 8: Faire** une coupe brisée.

EX8-

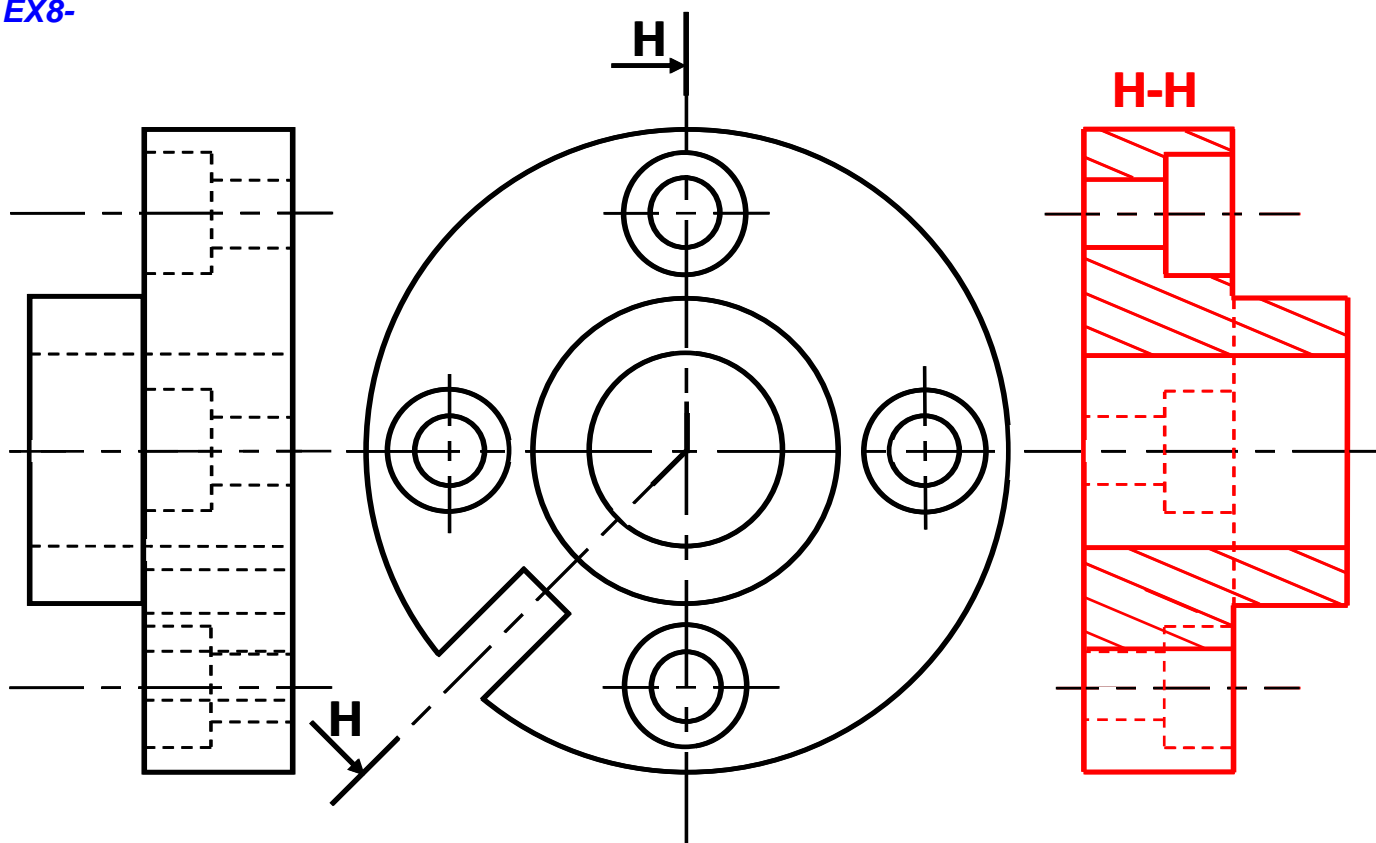

- EX9- ♦ Compléter :** - la vue de face coupe A-A ;
 - La vue de droite ;
 ♦ **Dessiner** la section sortie B-B.

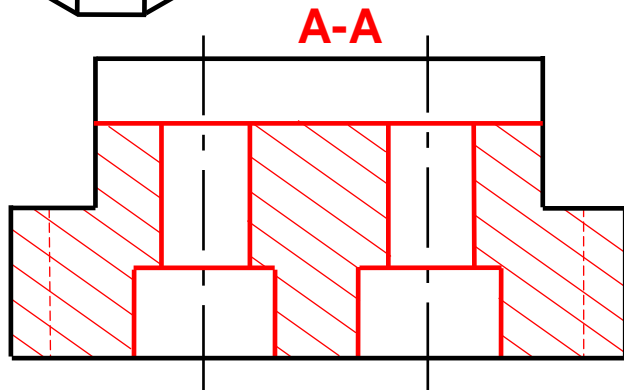
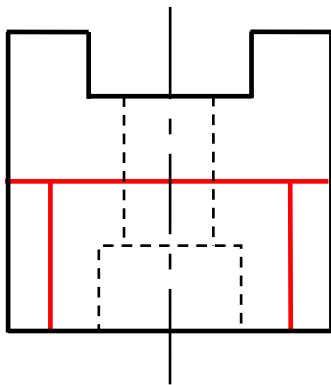
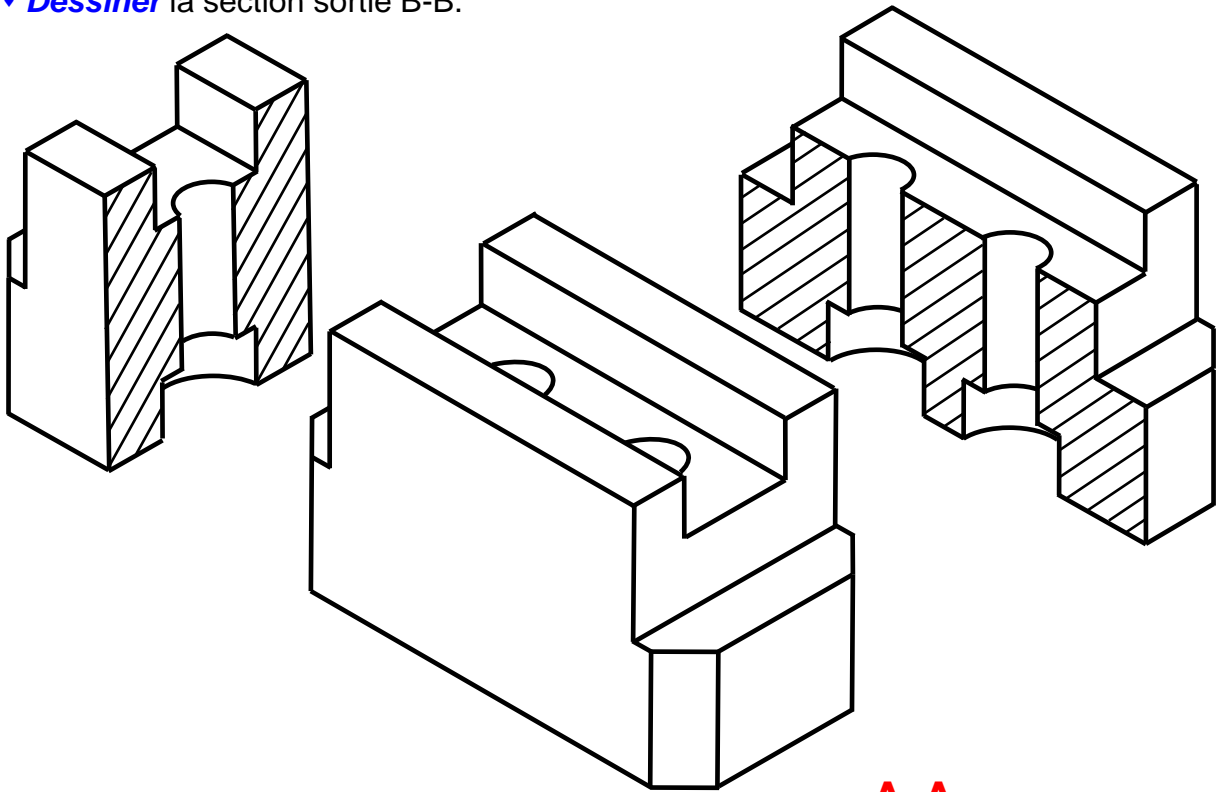

B-B

